

REVISIONS			
REV	DESCRIPTION	DATE	APPROVED
03 ₁	REDRAWN PER ECN 94-0474	9/15/95	JBJ 9/22/95 <i>S. Moly</i>
B	PER EC 0U20-0116-01-03	11/13/01	11/13/01 <i>C. Hoang</i>

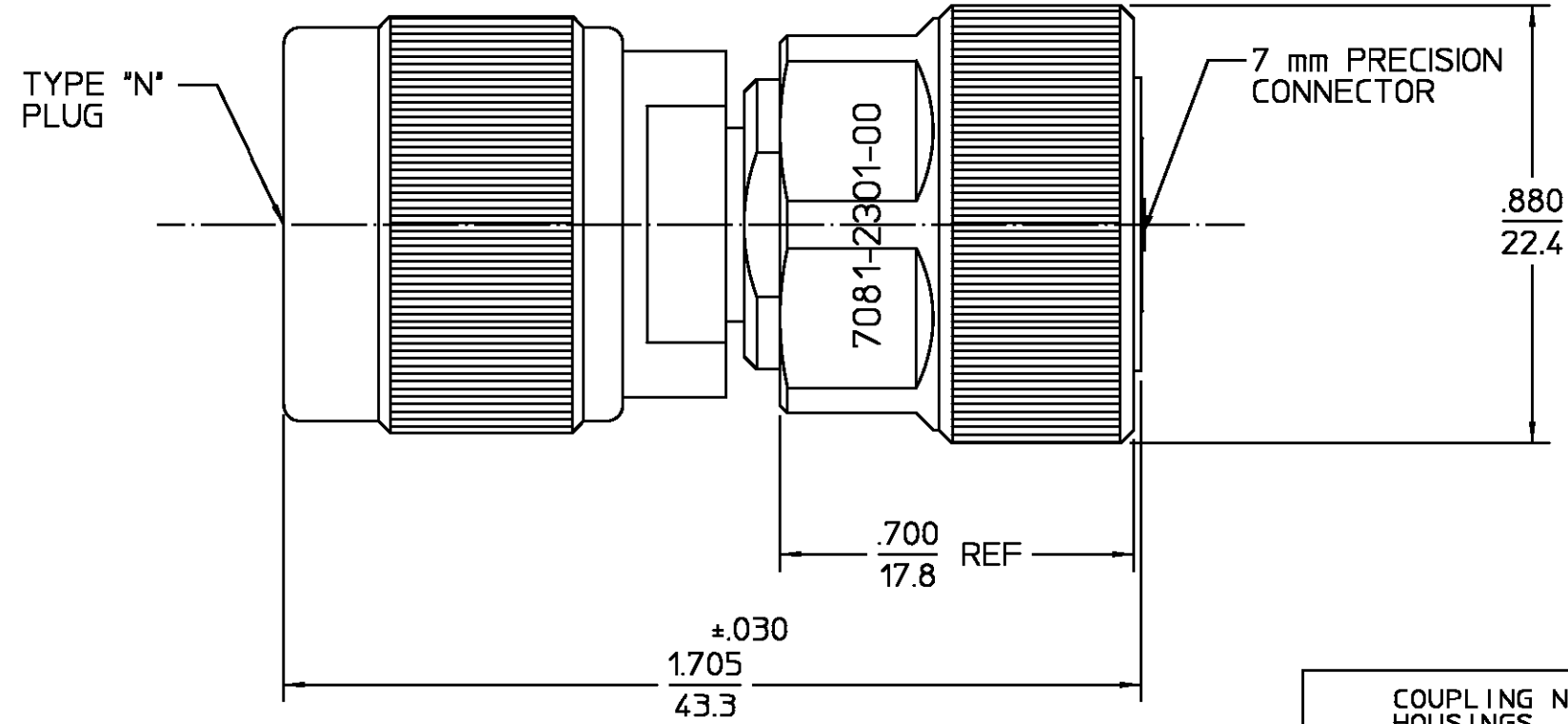

COUPLING NUTS HOUSINGS THREAD SLEEVE	STAINLESS STEEL PER ASTM-A484 AND ASTM- A582, TYPE 303	PASSIVATE PER QQ-P-35
CONTACT EXT.	BERYLLIUM COPPER PER ASTM-B-196 OR ASTM-B-197, ALLOY C17300, CONDITION H	GOLD PLATE PER MIL-G-45204
RETAINING RING	PHOSPHOR BRONZE PER QQ-B-750, GRADE B2	N/A
CENTER CONTACT	BRASS PER ASTM-B-16, HALF HARD	GOLD PLATE PER MIL-G-45204
COMPONENT	MATERIAL	FINISH

UNLESS OTHERWISE SPECIFIED DIMENSIONS ARE IN INCHES	DRAWN BY	BWC	DATE	11/8/67	AMP AMP Incorporated 140 Fourth Avenue Waltham, MA 02451-7599
	CHECKED BY	PRB	DATE	11/15/67	
FRAC. DEC. ANGLES ± 1/64 ±.005 ± 1°	APPD BY	EJD	DATE	11/15/67	
These drawings and specifications are the property of M/A COM Interconnect Div. and shall not be reproduced or copied or used in whole or in part as the basis for the manufacture or sale of item(s) without written permission.	.XXX = in XX.X = mm		TITLE 7 mm PRECISION TO TYPE N PLUG ADAPTER		
	SIZE	CODE IDENT NO.	7081-2301-00	REV	03 ₁
	SCALE	3:1		SHEET 1 OF 1	

CUSTOMER DRAWING

AMP PART # 1061738-1
SHEET 1 OF 1 REV B